

Intelligent LED Driver (Constant Current)

- Housing made from SAMSUNG/COVESTRO's V0 flame retardant PC materials.
- Ultra small, thin and lightweight, screwless end cap design.
- The output current, minimum brightness value, power-on fading time can be changed through the mobile NFC APP, realize the driver data interaction function.
- Leading edge (Triac), trailing edge (ELV) phase control dimming.
- Adjustable output current with 1mA step.
- Soft-on and fade-in dimming function enhances your visual comfort.
- T-PWM super deep dimming technology, 0.1% dimming depth
- The whole dimming process is flicker-free with high frequency exemption level.
- Overheat, over voltage, overload, short circuit protection and automatic recovery.
- Suitable for Class I/II/III indoor light fixtures.
- Normal service life can reach 100,000 hours.
- 5-year warranty (Rubycon capacitor).

DIM
T-PWM
Dimming Technology

Flicker Free
IEEE 1789

Dimmable:
1:1 0 0 0

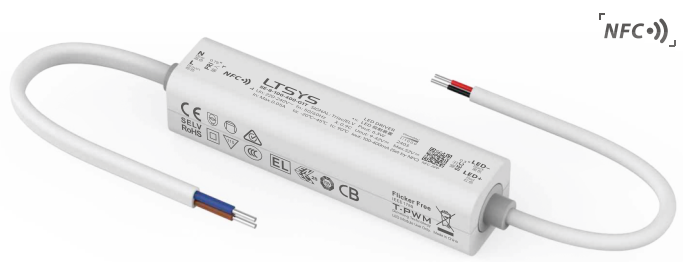

The certification icon represents undergoing certification applications only, and final certification qualification subject to actual product.



Technical Specs

| MODEL | SE-8-100-400-G1T | | SE-8-400-700-G1T | |
|--------------|----------------------------------|--|---|--|
| FEATURES | Output Type | Constant current | | |
| | Dimming Interface | Triac/ELV | | |
| | Output Feature | Isolation | | |
| | IP Rating | IP50 | | |
| | Insulation Glass | Class II (Suitable for class I/ II /III light fixtures) | | |
| OUTPUT | Output Voltage | 9-42Vdc | 2-15.5Vdc | |
| | Max. Output Voltage(No-load) | ≤52Vdc | ≤30Vdc | |
| | Output Current Range | 100-400mA | 400-700mA | |
| | Output Power Range | 0.8-6.3W | | |
| | Dimming Range | 0~100%, down to 0.1% | | |
| | LF Current Ripple | < 3% (Maximum current for non dimming state) | | |
| | Current Accuracy | ±5% | | |
| | PWM Frequency | ≤3600Hz | | |
| INPUT | AC Voltage Range | 220-240Vac | | |
| | DC Voltage Range | 220-240Vdc(EMI evaluation required after luminaire integration) | | |
| | Input Voltage | 230Vac | | |
| | Frequency | 50/60Hz | | |
| | Input Current | ≤0.045A/230Vac | | |
| | Power Factor | PF > 0.9/230Vac (at full load) | | |
| | Efficiency (Typ.) | > 72% | > 70% | |
| | Inrush Current | Cold start 10A(Test twidh=300us tested under 50% Ipeak)/230Vac | | |
| | Anti Surge | L-N:1KV | | |
| | Leakage Current | Max.0.5mA | | |
| ENVIRONMENT | Operating Temperature | ta:-20°C~45°C tc:90°C | | |
| | Working Humidity | 20~95%RH, non-condensing | | |
| | Storage Temperature/Humidity | -40~80°C/10~95%RH | | |
| | Temperature Coefficient | ±0.03%/°C(-20°C~45°C) | | |
| | Vibration | 10~500Hz, 2G 12min/1cycle, 72 min for X, Y and Z axes respectively | | |
| PROTECTION | Overload Protection | Automatically protect the device when the load exceeds 102% of the rated power. Automatically recover once load is reduced | | |
| | Overheat Protection | Intelligently adjust or turn off the current output if the PCB temperature ≥110°C. When the PCB temperature <90°C, automatically recover normal output | | |
| | Overvoltage Protection | Automatically protect the device when voltage exceeds the no-load voltage. It can be recovered automatically | | |
| | Short Circuit Protection | Enter hiccup mode if short circuit occurs, and recover automatically | | |
| SAFETY & EMC | Withstand Voltage | I/P-O/P: 3750Vac | | |
| | Insulation Resistance | I/P-O/P: 100MΩ/500VDC/25°C/70%RH | | |
| | Safety Certifications | CCC | China | GB19510.1, GB19510.14, GB19510.213 |
| | | TUV | Germany | EN61347-1, EN61347-2-13, EN62493 |
| | | CB | CB Member States | IEC61347-1, IEC61347-2-13 |
| | | CE | European Union | EN61347-1, EN61347-2-13, EN62384 |
| | | EAC | Russia | IEC61347-1, IEC61347-2-13 |
| | | RCM | Australia | AS 61347-1, AS 61347-2-13 |
| | | ENEC | Europe | EN61347-1, EN61347-2-13, EN62384 |
| | EMC Emission | CCC | China | GB/T17743, GB17625.1 |
| | | CE | European Union | ENIEC55015, ENIEC61000-3-2, EN61000-3-3 |
| | | EAC | Russia | IEC62493, IEC61547, EH55015 |
| | | RCM | Australia | EN55015, EN61000-3-2, EN61000-3-3, EN61547 |
| EMC Immunity | EN61000-4-2,3,4,5,6,8,11,EN61547 | | | |
| ErP | Power Consumption | Networked standby | Standby power consumption without network connection (when the thyristor signal is 0, the power consumption is 0) | |
| | | No-load power consumption | No no-load mode | |
| | Flicker/Stroboscopic Effect | IEEE1789 | Meet IEEE 1789 standard/High frequency exemption level | |
| | | CIE SVM | PstLM≤1.0, SVM≤0.4 | |
| | DF | Phase factor | DF≥0.9 | |
| OTHERS | Weight(N.W.) | 50g±5g | | |
| | Dimensions | 84x20x20mm(LxWxH) | | |

Product Size

Unit: mm

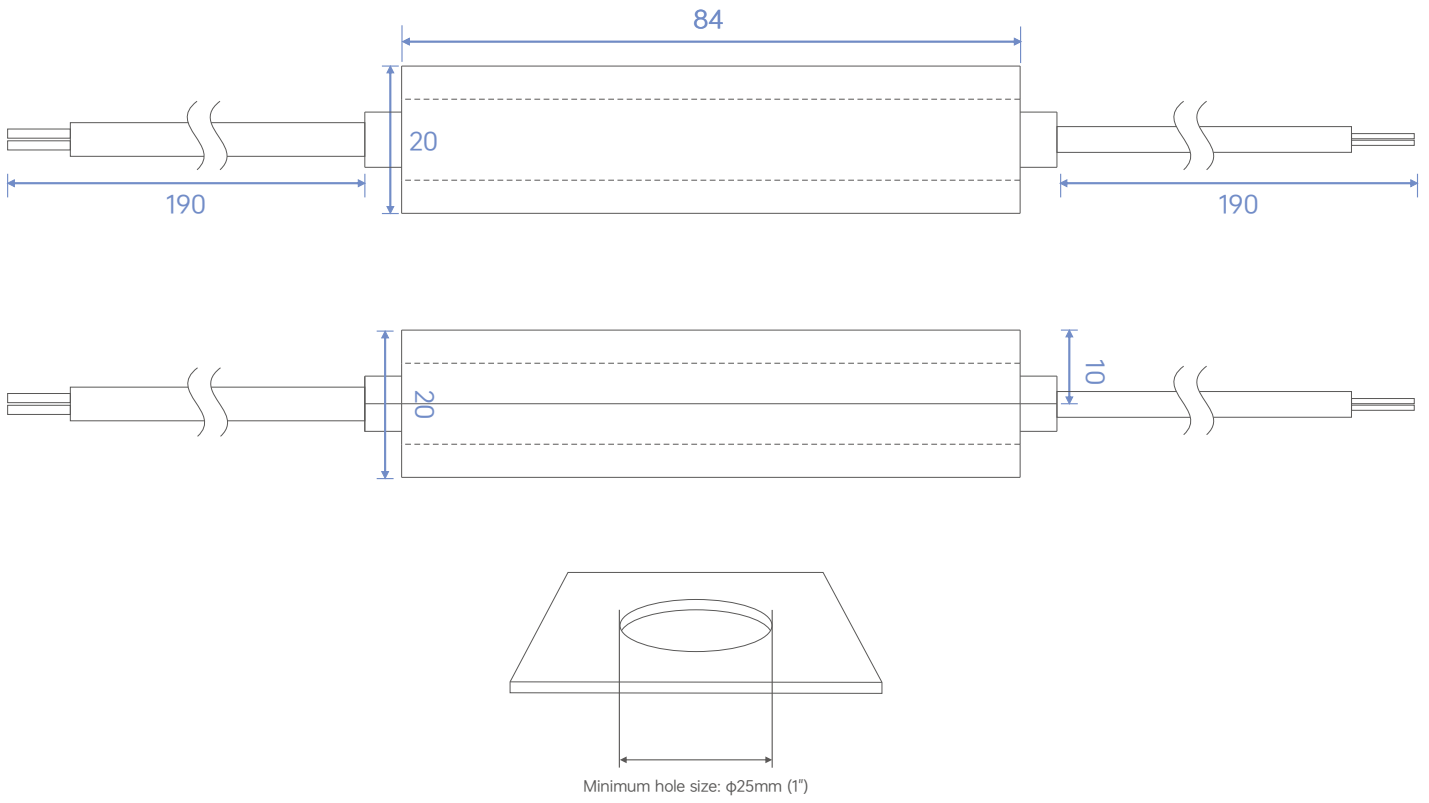

Wiring Diagram

Triac Connection

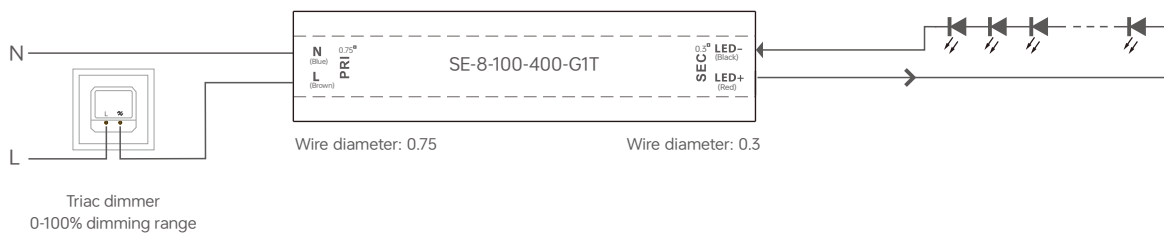

ELV Connection

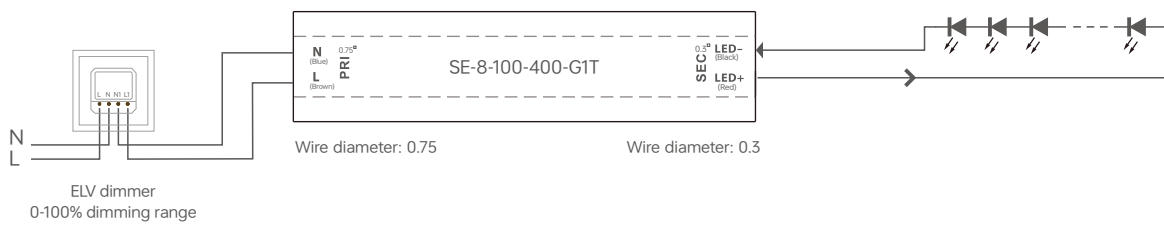

Typical Current Corresponding Parameter Table

The following 7 groups of typical current data are provided for model selection reference. More currents can be set via the mobile phone APP NFC. The settable range is 100-400mA, and the current step value can be as low as 1mA.

| | Output Current | 100mA | 150mA | 200mA | 250mA | 300mA | 350mA | 400mA |
|------------------|----------------|----------|-----------|-----------|------------|----------|-----------|-----------|
| SE-8-100-400-G1T | Output Voltage | 9-42Vdc | 9-42Vdc | 9-31.5Vdc | 9-25Vdc | 9-21Vdc | 9-18Vdc | 2-15.5Vdc |
| | Output Power | 0.9-4.2W | 1.35-6.3W | 1.8-6.2W | 2.25-6.25W | 2.7-6.3W | 3.15-6.3W | 0.8-6W |

The following 7 groups of typical current data are provided for model selection reference. More currents can be set via the mobile phone APP NFC. The settable range is 400-700mA, and the current step value can be as low as 1mA.

| | Output Current | 400mA | 450mA | 500mA | 550mA | 600mA | 650mA | 700mA |
|------------------|----------------|-----------|----------|-----------|-----------|-----------|-----------|----------|
| SE-8-400-700-G1T | Output Voltage | 2-15.5Vdc | 2-14Vdc | 2-12.5Vdc | 2-11.5Vdc | 2-10.5Vdc | 2-9.5Vdc | 2-9Vdc |
| | Output Power | 0.8-6W | 0.9-6.3W | 1-6W | 1.1-6.05W | 1.2-6W | 1.3-5.85W | 1.4-6.3W |

Surge Current & Corresponding Miniature Circuit Breaker (MCB) Load Capacity Table

| MCB Model | B10 | B13 | B16 | B20 | B25 | C10 | C13 | C16 | C20 | C25 | D10 | D13 | D16 | D20 | D25 |
|-----------------------|-----|-----|-----|-----|-----|-----|-----|-----|-----|-----|-----|-----|-----|-----|-----|
| Maximum Load Capacity | 20 | 26 | 32 | 40 | 40 | 23 | 30 | 37 | 47 | 58 | 27 | 34 | 42 | 53 | 66 |

Remarks:

1. Test Conditions: Cold start 10A(Test twidth=300us tested under 50% Ipeak)/230Vac
- 2.The number of supported drivers may vary depending on the brand and model of the MCB.
- 3.It is recommended not to exceed the specified load capacity during on-site installation. The actual load should be determined based on field conditions.
- 4.If the ambient temperature exceeds 30°C or multiple MCBs are installed side by side, the number of installed drivers must be reduced and recalculated accordingly.
- 5.Electricians typically use Type B MCBs for residential lighting and Type C MCBs for commercial lighting applications.
- 6.Different testing equipment may yield variations in measured current peaks and pulse widths. Always use professional-grade instruments for accurate testing.

Installation Precautions

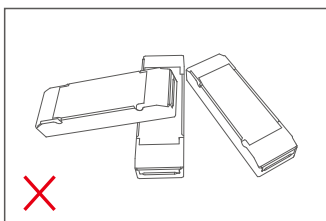

Please do not stack the products. The distance between two products should be $\geq 15\text{cm}$ so as not to affect heat dissipation and the lifespan of the products.

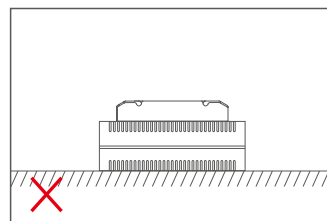
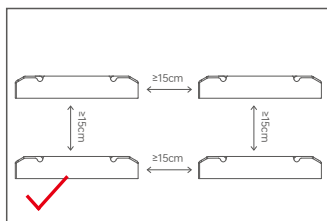

Please not place the products on LED drivers. The distance between the product and the driver should be $\geq 15\text{cm}$ so as not to affect heat dissipation and shorten the lifespan of the products.

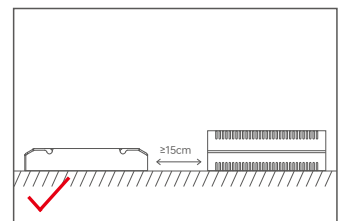

Note: The installation should be in line with the environmental operating temperature of the product. Do not install it inside the lamp to avoid exceeding the environmental operating temperature of the product, which may affect the product's lifespan.

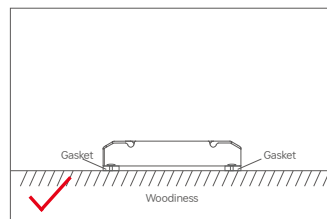
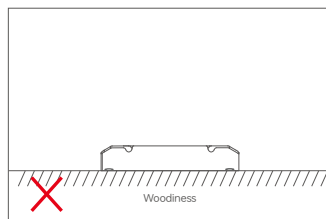

Do not fix the product screws tightly against the wooden board. Instead, add a washer with a thickness of $\geq 7\text{mm}$ under the fixing screws. Leaving some gaps can effectively dissipate heat, preventing any impact on the product's heat dissipation performance and service life.

Use the NFC Lighting APP

Scan the QR code below with your mobile phone and follow the prompts to complete the APP installation (According to performance requirements, you need to use a NFC-capable Android phone, or an iPhone 8 and later that are compatible with iOS 13 or higher).



* Before you begin setting the parameters of the driver, please ensure the driver is powered off.

Read/Write the LED driver

Use your NFC-capable phone to read LED driver data, then edit the parameters and they can be directly written to the driver.

1. Read the LED driver

On the APP home page, click **【Read/Write LED driver】**, then keep the programmer's sensing area close to the NFC logo of the driver to read the driver parameters.

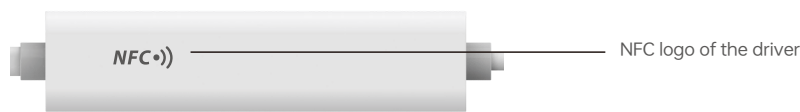

2. Edit the parameters

Click **【Parameter settings】** to edit the Output current, Min level, Power-on fading time and more advanced parameters.

3. Write to the driver

After completing the parameter settings, click **【Write】** in the upper right corner, and keep the programmer's sensing area close to the NFC logo of the driver, so the parameters can be written to the driver.

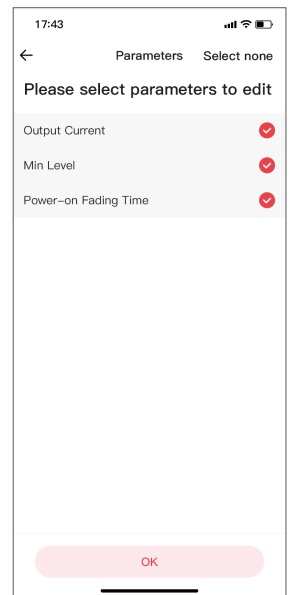
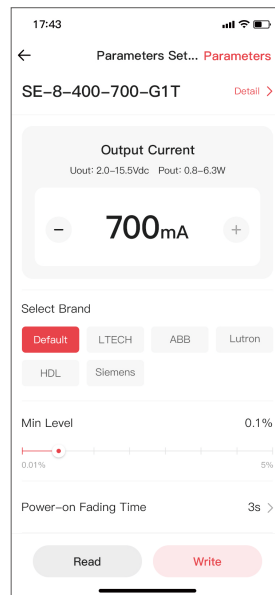
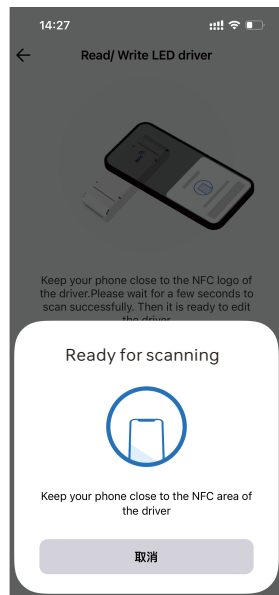

Relationship Diagrams

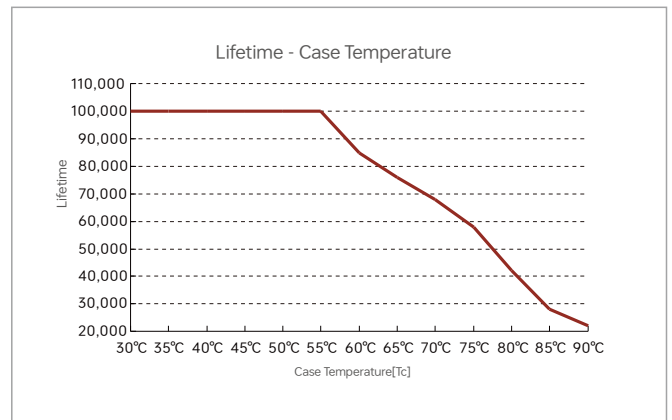
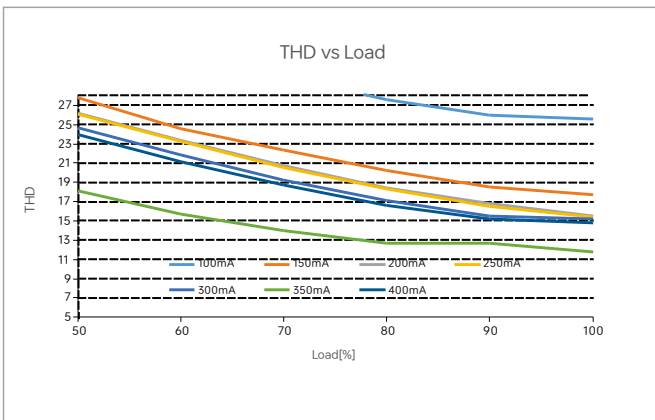
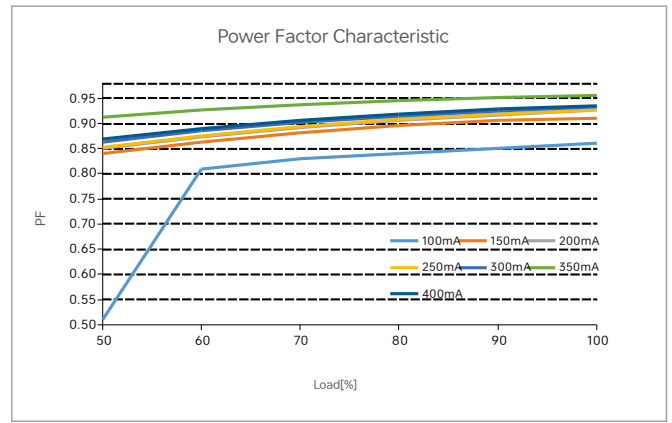
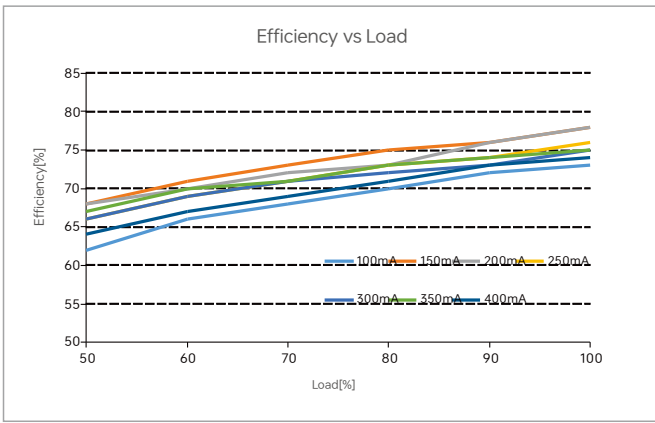

SE-8-100-400-G1T

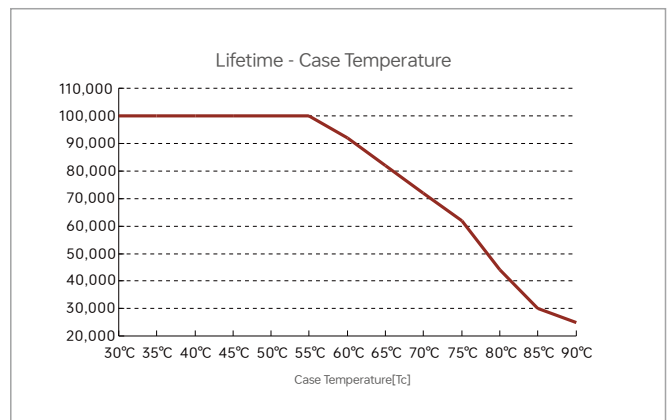
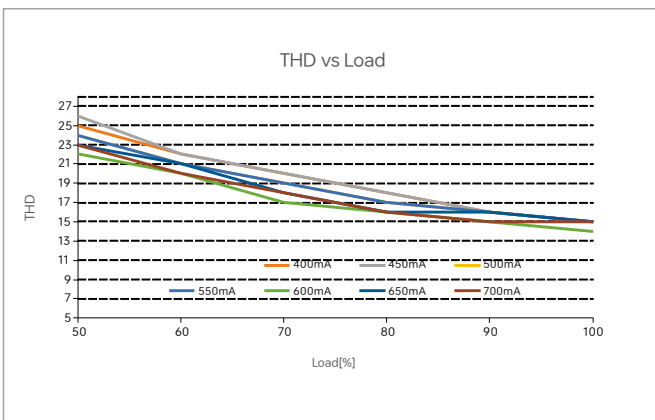
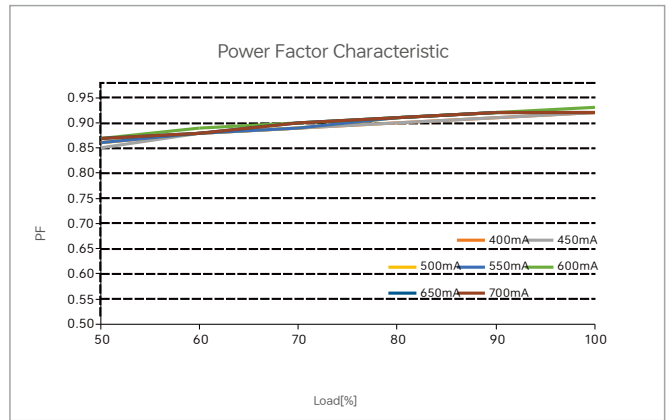
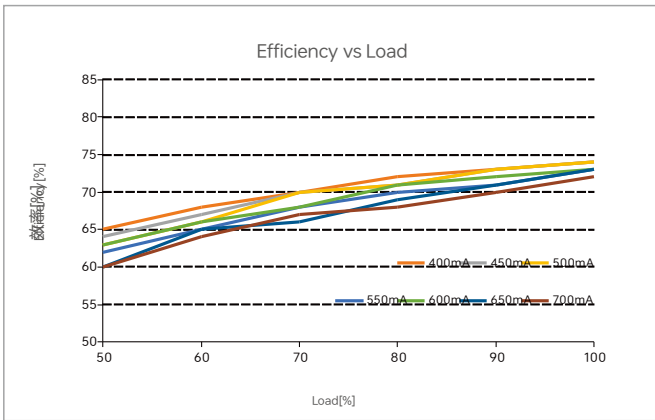

SE-8-400-700-G1T

Flicker Test Sheet

IEEE 1789

| Limit of modulation in low risk area | |
|---------------------------------------|---|
| Waveform frequency of optical output | limit (%) |
| $f \leq 8\text{Hz}$ | 0.2 |
| $8\text{Hz} < f \leq 90\text{Hz}$ | $0.025 \times f$ |
| $90\text{Hz} < f \leq 1250\text{Hz}$ | $0.08 \times f$ |
| $f > 1250\text{Hz}$ | Exemption assessment |
| Limit of modulation in no effect area | |
| Waveform frequency of optical output | limit (%) |
| $f \leq 10\text{Hz}$ | 0.1 |
| $10\text{Hz} < f \leq 90\text{Hz}$ | $0.01 \times f$ |
| $90\text{Hz} < f \leq 3125\text{Hz}$ | $(0.08/2.5) \times f$ |
| $f > 3125\text{Hz}$ | Exemption assessment (High frequency exemption) |

- Brightness
- ▲ 0.1%
 - ◆ 1%
 - ▲ 5%
 - ◆ 10%
 - 20%
 - ▲ 30%
 - 40%
 - ★ 50%
 - 60%
 - 70%
 - 80%
 - ★ 90%
 - ◆ 100%

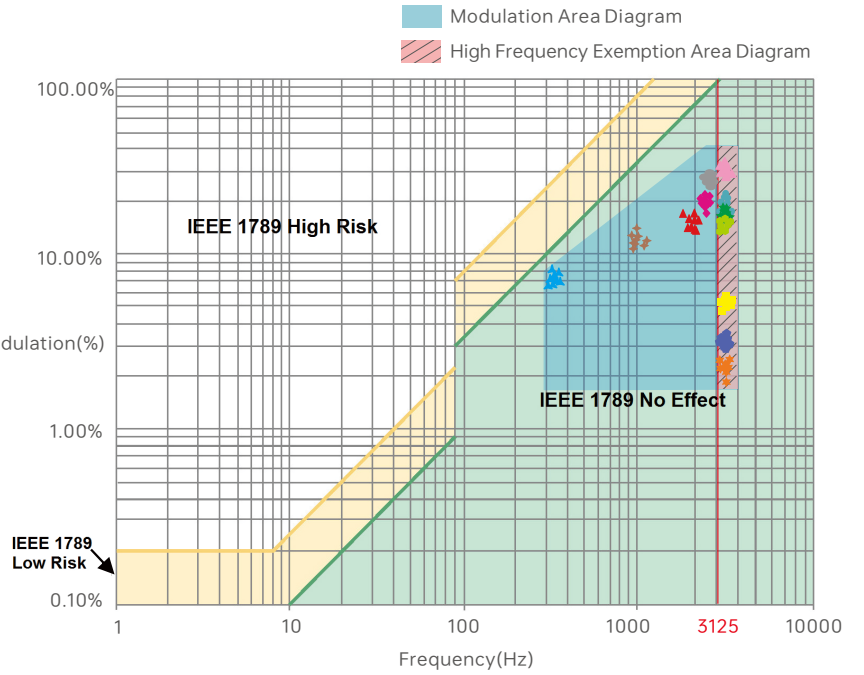

Marks in the right chart were tested results of different current ranges. The output frequency is 0Hz in 100% brightness and its corresponding modulation is 0%, which could not be shown in the right chart.

Packaging Specifications

| | |
|-------------------|---|
| Model | SE-8-100-400-G1T/SE-8-400-700-G1T |
| Carton Dimensions | 385×245×160mm(L×W×H) |
| Quantity | 20 PCS/Layer; 5 Layers/Carton; 100 PCS/Carton |
| Weight | 0.055kg/PC;5.5kg/Box |

Packaging Image

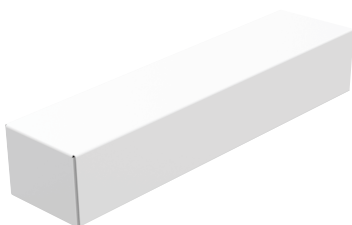

Inner Packaging Box



Carton Packaging

Transportation and Storage

1. Transportation

Products can be shipped via vehicles, boats and planes.

During transportation, products should be protected from rain and sun. Please avoid severe shock and vibration during the loading and unloading process.

2. Storage

The storage conditions should comply with the Class I Environmental Standards. The products that have been stored for more than six months are recommended to be re-inspected and can be used only after they have been qualified.

Attentions

- This product must be installed and adjusted by a qualified professional.
- This product is non-waterproof (special models excepted). Please avoid the sun and rain. When installed outdoors, please ensure it is mounted in a water proof enclosure.
- Good heat dissipation will extend the life the product. Please install the product in a environment with good ventilation.
- When you install this product, please avoid being near a large area of metal objects or stacking them to prevent signal interference.
- Please keep the product away from a intense magnetic field, a high pressure area or a place where lightning is easy to occur.
- Please check whether the working voltage used complies with the parameter requirements of the product.
- Before you power on the product, please make sure all the wiring is correct in case of incorrect connection that may cause a short circuit and damage the components, or trigger a accident.
- If a fault occurs, please do not attempt to fix the product by yourself. If you have any question, please contact the supplier.

* This manual is subject to changes without further notice. Product functions depend on the goods. Please feel free to contact our official distributors if you have any question.

Warranty Agreement

- Warranty periods from the date of delivery: 5 years.
- Free repair or replacement services for quality problems are provided within warranty periods.

Warranty exclusions below:

- Beyond warranty periods.
- Any artificial damage caused by high voltage, overload, or improper operations.
- Products with severe physical damage.
- Damage caused by natural disasters and force majeure.
- Warranty labels and barcodes have been damaged.
- No any contract signed by LTECH.

1. Repair or replacement provided is the only remedy for customers. LTECH is not liable for any incidental or consequential damage unless it is within the law.
2. LTECH has the right to amend or adjust the terms of this warranty, and release in written form shall prevail.

Update Log

| Version | Updated Time | Update Content | Updated by |
|---------|--------------|------------------|------------|
| A0 | 20250429 | Original version | Li Haipeng |

LED智能调光驱动器(恒流型)

- 外壳采用科思创/三星PC阻燃V0级原料;
- 超小体积、轻薄、免螺丝端盖设计;
- 使用手机APP通过NFC可更改输出电流、最低亮度值、通电渐变时间等, 实现驱动器数据交互功能;
- 前沿(Triac), 后沿(ELV)切相调光;
- 电流步进值低至1mA, 兼容性更高更精细;
- 带软启动渐亮功能, 让人眼视觉更舒服;
- T-PWM 超深度调光技术, 调光深度可达0.1%;
- 0-100%全程调光无可视频闪, 高频豁免考核级别;
- 过温、过载、短路保护, 可自动恢复;
- 适合室内I、II、III类灯具应用;
- 常规使用下寿命可达10万小时;
- 5年保修期(红宝石电容);

调光

T-PWM
超深度调光技术

无频闪
IEEE1789
高频豁免考核级别

Dimmable:
1:1000



认证图标仅代表产品正在进行一系列的认证申请, 认证资质以产品实物为准。

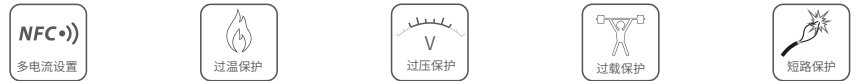

技术参数

| 型号 | SE-8-100-400-G1T | SE-8-400-700-G1T | | |
|---------|----------------------------------|---|---------------------------|---|
| 特征 | 输出类型 | 恒流 | | |
| | 调光接口 | Triac/ELV | | |
| | 输出特征 | 隔离 | | |
| | 防护等级 | IP50 | | |
| 输出 | 绝缘等级 | II类(适用于室内I、II、III类灯具) | | |
| | 输出电压 | 9-42Vdc | 2-15.5Vdc | |
| | 最大输出电压(空载) | ≤52Vdc | ≤30Vdc | |
| | 工作电流范围 | 100-400mA | 400-700mA | |
| | 负载功率范围 | 0.8-6.3W | | |
| | 调光范围 | 0~100%, 调光深度:0.1% | | |
| | 电流纹波 | < 3% (输出最大电流非调光状态) | | |
| | 电流精度 | ±5% | | |
| 输入 | PWM调光频率 | ≤3600Hz | | |
| | 交流电压范围 | 220-240Vac | | |
| | 直流电压范围 | 220-240Vdc(EMI需配灯具后评估) | | |
| | 额定电压 | 230Vac | | |
| | 频率范围 | 50/60Hz | | |
| | 输入电流 | ≤0.045A/230Vac | | |
| | 功率因数 | PF > 0.9/230Vac(满载) | | |
| | 效率(Typ.) | 72% | 70% | |
| | 浪涌电流 | 冷启动10A(在50%peak下测twidth=300us)@230Vac | | |
| | 抗浪涌 | L-N:1KV | | |
| 环境 | 漏电流 | Max.0.5mA | | |
| | 工作温度 | ta:-20°C~45°C tc:90°C | | |
| | 工作湿度 | 20~95%RH, 无冷凝 | | |
| | 储存温度/湿度 | -40~80°C/10~95%RH | | |
| | 温度系数 | ±0.03%/°C(-20°C~45°C) | | |
| 保护 | 耐振动 | 10-500HZ, 2G 12分钟/周期, X,Y,Z轴各72分钟 | | |
| | 过载保护 | 负载超过额定功率≥1.02倍时自动保护, 减轻负载自动恢复 | | |
| | 过温保护 | 根据PCB温度超标情况(≥110°C), 智能调节电流输出或关闭, 可自动恢复; PCB温度 < 90°C时, 可自动恢复正常输出 | | |
| | 过压保护 | 超过空载电压值进入保护, 可自行恢复 | | |
| | 短路保护 | 输出线路短路进入打嗝模式, 可自动恢复 | | |
| 安规和电磁规格 | 耐压 | 输入对输出: 3750Vac | | |
| | 绝缘阻抗 | 输入对输出: 100MΩ/500VDC/25°C/70%RH | | |
| | 安全规范 | CCC | 中国 | GB19510.1, GB19510.14, GB19510.213 |
| | | TUV | 德国 | EN61347-1, EN61347-2-13, EN62493 |
| | | CB | CB成员国 | IEC61347-1, IEC61347-2-13 |
| | | CE | 欧盟 | EN61347-1, EN61347-2-13, EN62384 |
| | | KC | 韩国 | KC61347-1, KC61347-2-13 |
| | | EAC | 俄罗斯 | IEC61347-1, IEC61347-2-13 |
| | | RCM | 澳洲 | AS 61347-1, AS 61347-2-13 |
| | | ENEC | 欧洲 | EN61347-1, EN61347-2-13, EN62384 |
| | 电磁兼容发射 | BIS | 印度 | IS 15885 (PART 2/SEC 13) |
| | | CCC | 中国 | GB/T17743, GB17625.1 |
| | | CE | 欧盟 | ENIEC55015, ENIEC61000-3-2, EN61000-3-3 |
| | | KC | 韩国 | KSC 9815, KSC 9547 |
| | | EAC | 俄罗斯 | IEC62493, IEC61547, EH55015 |
| RCM | 澳洲 | EN55015, EN61000-3-2, EN61000-3-3, EN61547 | | |
| 电磁兼容抗扰度 | EN61000-4-2,3,4,5,6,8,11,EN61547 | | | |
| ErP | 功耗 | 网络待机功耗 | 无网络待机功耗(可控硅信号为0时, 电源功耗为0) | |
| | 空载功耗 | 无空载模式 | | |
| | 频闪/频闪效应 | IEEE1789 | 满足无影响/高频豁免考核级别 | |
| 其他 | CIE SVM | PstLM≤1.0, SVM≤0.4 | | |
| | DF | 相位因素 DF≥0.9 | | |
| 其他 | 产品重量 | 50g±5g | | |
| | 产品尺寸 | 84x20x20mm(LxWxH) | | |

尺寸图

单位:mm

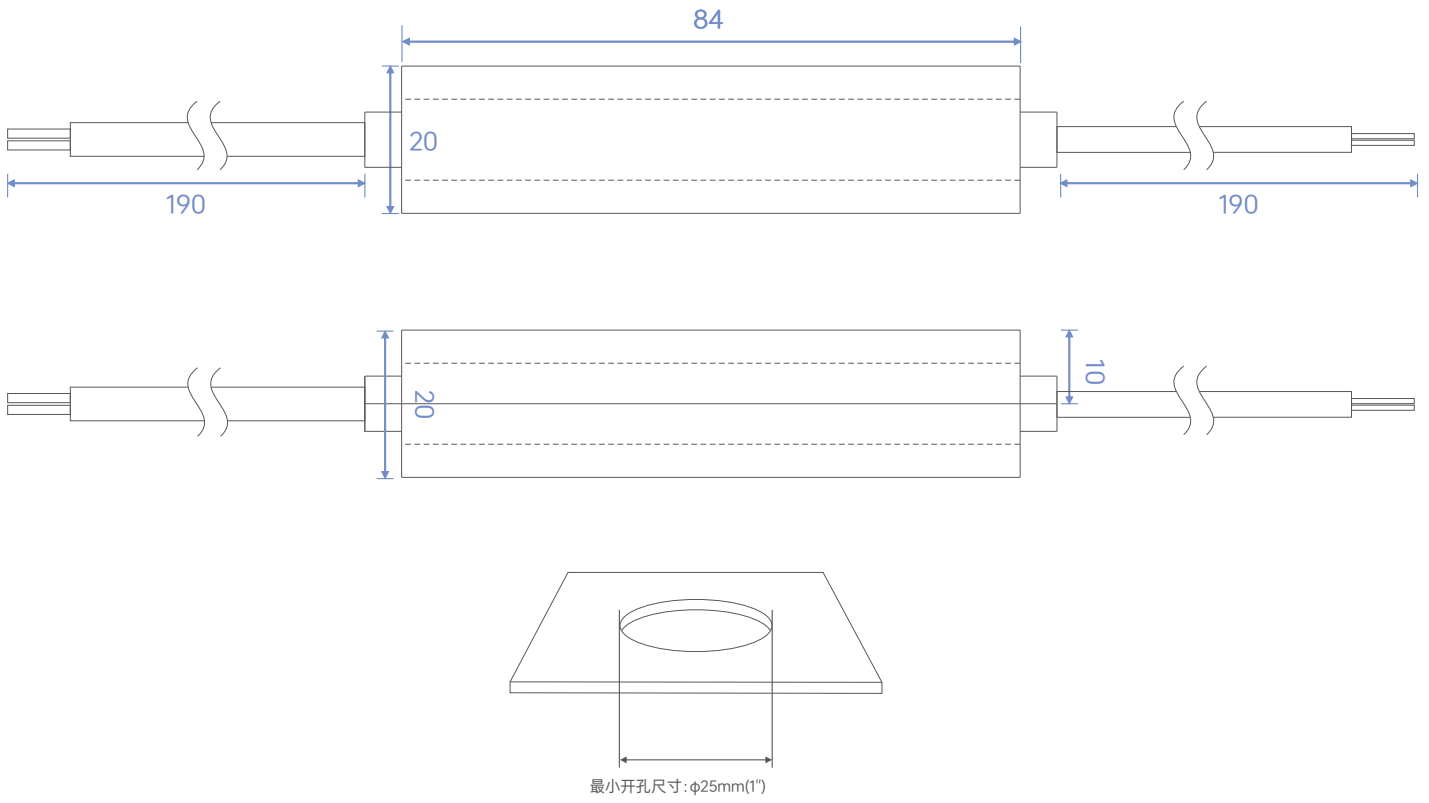

连接应用图

Triac连接方式



ELV连接方式



典型电流对应参数表

下图典型7组电流数据供选型参考，均可通过手机APP NFC设置更多电流，可设置范围在100-400mA，电流步进值低至1mA

| SE-8-100-400-G1T | 输出电流 | 100mA | 150mA | 200mA | 250mA | 300mA | 350mA | 400mA |
|------------------|------|----------|-----------|-----------|------------|----------|-----------|-----------|
| | 输出电压 | 9-42Vdc | 9-42Vdc | 9-31.5Vdc | 9-25Vdc | 9-21Vdc | 9-18Vdc | 2-15.5Vdc |
| | 输出功率 | 0.9-4.2W | 1.35-6.3W | 1.8-6.2W | 2.25-6.25W | 2.7-6.3W | 3.15-6.3W | 0.8-6W |

下图典型7组电流数据供选型参考，均可通过手机APP NFC设置更多电流，可设置范围在400-700mA，电流步进值低至1mA

| SE-8-400-700-G1T | 输出电流 | 400mA | 450mA | 500mA | 550mA | 600mA | 650mA | 700mA |
|------------------|------|-----------|----------|-----------|-----------|-----------|-----------|----------|
| | 输出电压 | 2-15.5Vdc | 2-14Vdc | 2-12.5Vdc | 2-11.5Vdc | 2-10.5Vdc | 2-9.5Vdc | 2-9Vdc |
| | 输出功率 | 0.8-6W | 0.9-6.3W | 1-6W | 1.1-6.05W | 1.2-6W | 1.3-5.85W | 1.4-6.3W |

浪涌电流&对应的微型断路器(MCB)下挂载的数量对应表

| 微型断路器型号 | B10 | B13 | B16 | B20 | B25 | C10 | C13 | C16 | C20 | C25 | D10 | D13 | D16 | D20 | D25 |
|---------|-----|-----|-----|-----|-----|-----|-----|-----|-----|-----|-----|-----|-----|-----|-----|
| 最大带载数量 | 20 | 26 | 32 | 40 | 40 | 23 | 30 | 37 | 47 | 58 | 27 | 34 | 42 | 53 | 66 |

备注:

1. 本数据测试条件: 冷启动10A(在50%peak下测twidth=300us)@230Vac;
2. 对于不同品牌和型号的微型断路器, 驱动器的数量会有所不同;
3. 现场安装时建议不要超过上述数量, 具体负载量以现场安装为准;
4. 当微型断路器的安装环境温度超过30°C或多个微型断路器并排安装时, 安装的驱动器数量将减少, 这需要重新计算;
5. 电工通常考虑将B型MCB用于家用照明, 将C型MCB用于商业照明;
6. 不同仪器设备测试出来的电流峰值和脉冲宽度有差异, 请使用专业仪器设备测试;

安装注意事项

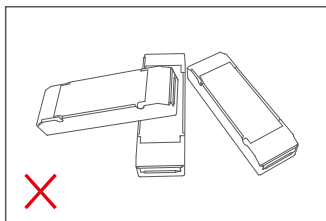

请勿将产品堆叠摆放, 产品与产品间隔距离应 $\geq 15\text{cm}$, 避免影响产品散热和使用寿命。

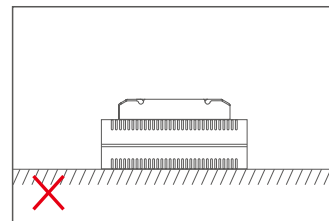
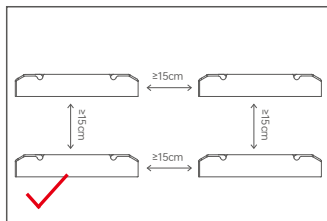

请勿将产品置于电源上面, 与电源间隔距离应 $\geq 15\text{cm}$, 避免影响产品散热而减少使用寿命。

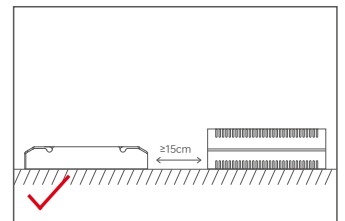

注: 安装需符合产品的环境工作温度, 切勿安装到灯具内部, 以免超出产品环境工作温度影响产品寿命。

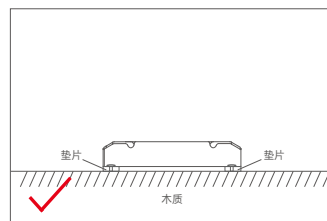
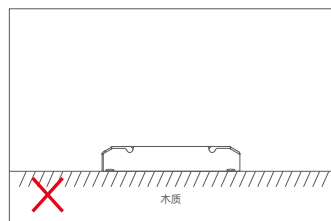

请勿将产品螺丝固定紧贴于木板, 应在固定螺丝下增加 $\geq 7\text{mm}$ 的垫片, 留点空隙可以有效散热, 避免影响产品散热和使用寿命。

搭配 NFC Lighting APP 使用

通过手机扫描下载二维码，按提示完成APP安装。(因性能需求，要求手机型号苹果：iPhone 8及以上、且操作系统iOS13及以上； 安卓：具备NFC功能机型)



* 设置驱动器参数时，必须在驱动器断电情况下进行操作。

读/写智能电源

使用手机，通过NFC读取驱动器信息，根据需求设置参数后，可直接写入驱动器。

1. 读取驱动器

在APP“首页”点击【读/写智能电源】，将手机感应区域靠近驱动器NFC标识点，读取驱动器参数。

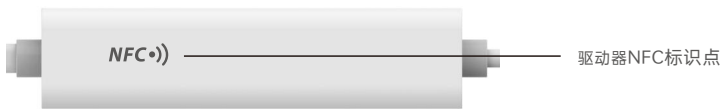

2. 编辑参数

点击【参数管理】可编辑输出电流、最低亮度值、通电渐变时间等更多高级参数。

3. 写入驱动器

参数设置完成后，点击右上角【写入】，将手机感应区域靠近驱动器NFC标识点，即可写入驱动器成功修改参数。



关系图表

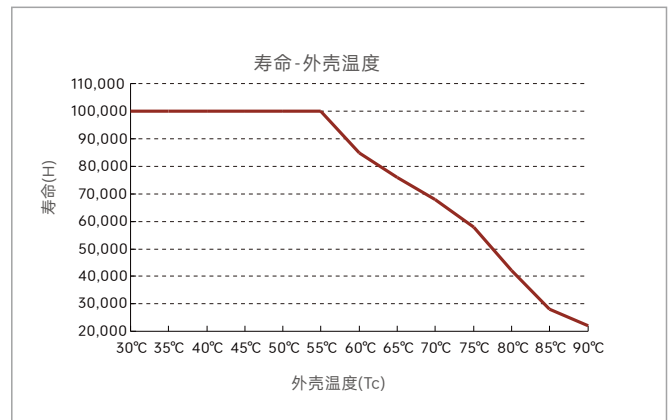
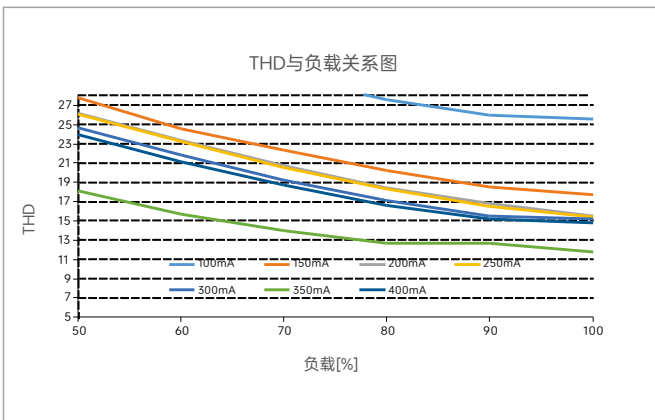
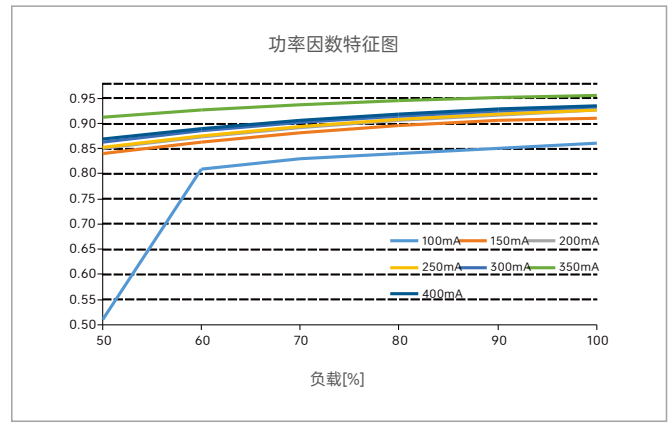
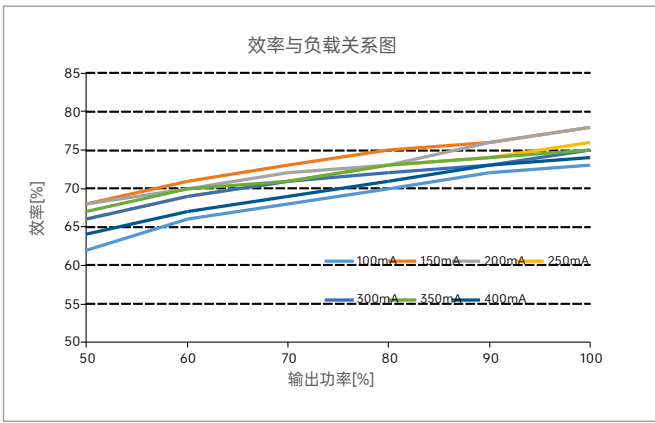

SE-8-100-400-G1T

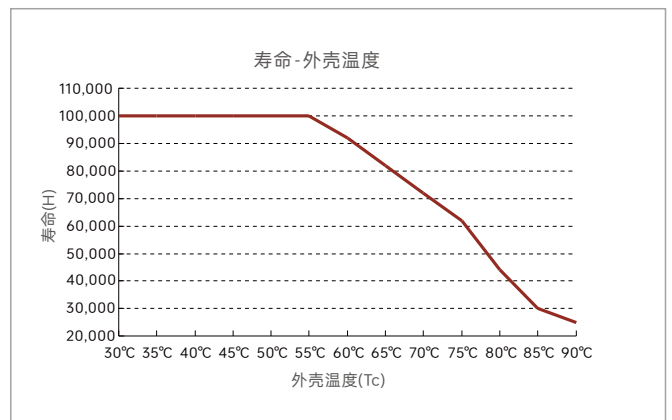
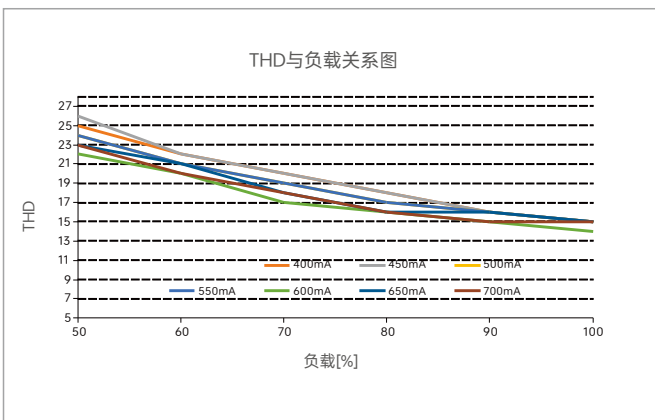
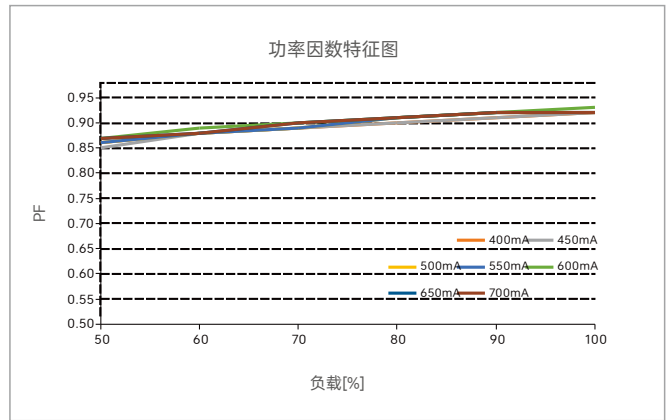
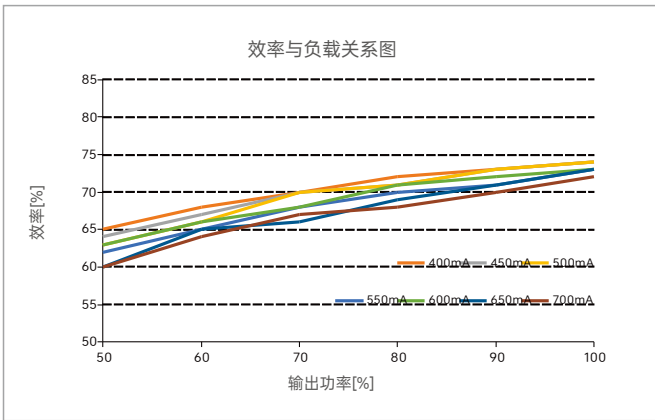

SE-8-400-700-G1T

频闪测试表

IEEE1789

| 低风险区域 (LowRisk) 的波动深度 (Modulation) 限值 | |
|--|-----------------------|
| 光输出波形频率 f | 限值 (%) |
| $f \leq 8\text{Hz}$ | 0.2 |
| $8\text{Hz} < f \leq 90\text{Hz}$ | $0.025 \times f$ |
| $90\text{Hz} < f \leq 1250\text{Hz}$ | $0.08 \times f$ |
| $f > 1250\text{Hz}$ | 免除考核 |
| 无风险区域 (NoEffect) 的波动深度 (Modulation) 限值 | |
| 光输出波形频率 f | 限值 (%) |
| $f \leq 10\text{Hz}$ | 0.1 |
| $10\text{Hz} < f \leq 90\text{Hz}$ | $0.01 \times f$ |
| $90\text{Hz} < f \leq 3125\text{Hz}$ | $(0.08/2.5) \times f$ |
| $f > 3125\text{Hz}$ | 免除考核 (高频豁免) |

- 亮度
- ▲ 0.1%
 - ◆ 1%
 - ▲ 5%
 - ◆ 10%
 - 20%
 - ▲ 30%
 - 40%
 - ★ 50%
 - 60%
 - 70%
 - 80%
 - ★ 90%
 - ◆ 100%

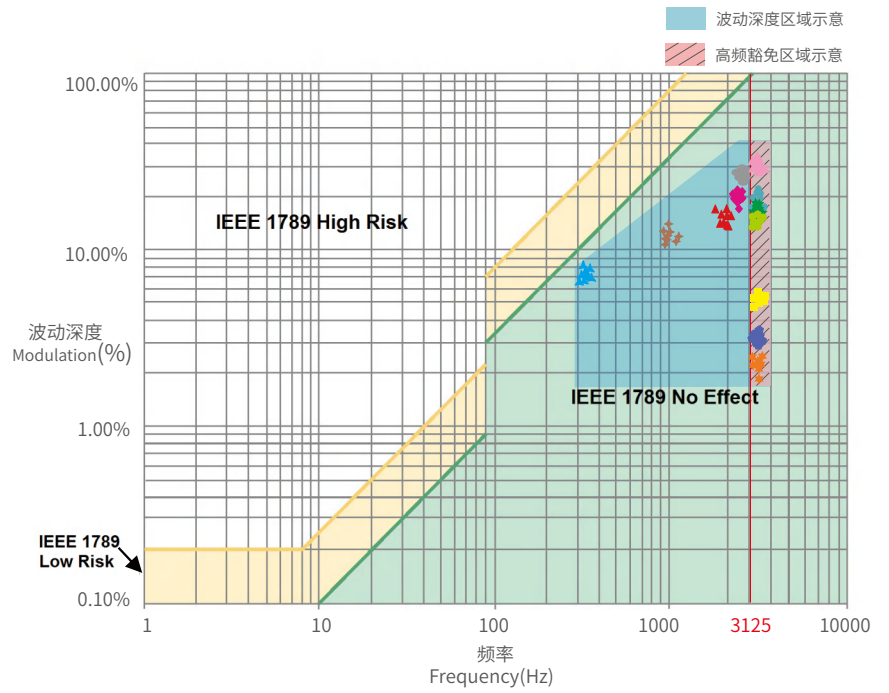

右图标识为不同电流档的测试结果。

100%亮度时输出频率为0Hz，对应波动深度为0%，无法在右图中示意。

包装规格

| | |
|-------|-----------------------------------|
| 型号 | SE-8-100-400-G1T/SE-8-400-700-G1T |
| 包装箱尺寸 | 385×245×160mm(L×W×H) |
| 数量 | 20PCS/层; 5层/箱; 100PCS/箱 |
| 重量 | 0.055kg/PC; 5.5kg/箱 |

包装样式图

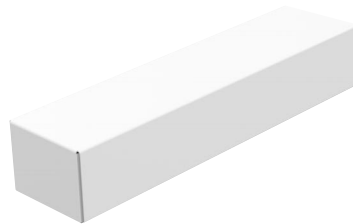

内包装盒



整箱包装

运输和贮存

1.运输

产品适用车、船、飞机交通运输工具运输。

在运输中，应使用遮篷进行防雨和防晒，并保持文明装卸，不应有剧烈振动、撞击等。

2.贮存

贮存符合类环境的规定。贮存期限超过6个月的产品建议重新检验，合格后方可使用。

注意事项

- 本产品本产品请由具有专业资格的人员进行调试安装；
- 本产品(专有型号除外)不能防水，需避免日晒雨淋。如安装在户外，请使用防水箱；
- 良好的散热条件会延长产品的使用寿命，请把产品安装在通风良好的环境；
- 安装时，避免靠近大面积金属物体，或堆叠摆放，以免信号干扰影响使用；
- 避免安装在雷区、强磁场和高压区域；
- 请检查使用的工作电压是否符合产品的参数要求；
- 通电调试前，确保所有接线正确且牢固，以免短路损坏部件，触发事故；
- 如果发生故障，请勿私自维修；如有疑问，请联系供应商。

* 本说明书的内容如有变更，恕不另行通知。若内容与您使用的功能有所不同，则以实物为准。如有疑问，欢迎向我司授权的经销商咨询。

保修条例

- 自出厂之日起保修服务期为5年。
- 在保修服务期内出现产品质量问题雷特将给予免费修理或更换服务。

无保修条例:

属下列情况不在免费保修或更换服务范围之内:

- 已经超出保修服务期;
- 过高电压、超负载、操作不当等行为造成的损坏;
- 产品外形严重损坏或变形;
- 自然灾害以及人力不可抗拒原因造成的损坏;
- 产品保修标签和产品唯一条形码损坏;
- 无雷特签订的合同或发票凭证。

1.修理或更换是雷特对客户的一补救措施。雷特不承担任何附带引起的损害赔偿,除非在适用法律范围之内。

2.雷特享有修正或调整本保修条款的权利,并以书面形式发布为准。

更新日志

| 版本 | 更改日期 | 更改内容 | 更改人 |
|----|----------|------|-----|
| A0 | 20250307 | 正稿 | 黎海鹏 |